

www.cacc-china.com

Síguenos en: / Follow us on: / Suivez-nous sur :



Room 301, Floor 3, No. 23, Baili Road, Bantian Avenue,
Longgang District, Shenzhen
T:0755-22309198

E-mail : shenzhen@cacc-china.com
Shenzhen Taste Fashion Cooking Technology Co.,Ltd
www.cacc-china.com

深圳市龙岗区坂田街道百利路23号
电话 : 0755-22309198
邮箱 : shenzhen@cacc-china.com
深圳市品尚烹饪技术有限公司

CREATIVECHEF®

◆ From Spain ◆



2019/01

Taurus Professional ROWZER
Taurus Professional MYCOOK1.8
SOUS VIDE
Vacuum Packaging Machinery
Bags especially Designed for SOUS VIDE
Vacuum Bags of Food Packaging
ISI Whip Product /SMOKING TOOL

万能冰磨机 / 多功能食品料理机
低温慢煮机 / 真空包装机
低温慢煮专用袋 / 食品真空包装袋
ISI奶油瓶/烟熏机



Shenzhen Taste Fashion Cooking Technology Limited Company was founded in 2008. We are an unique professional company which focuses on "fashion food and beverage equipment, fashion gear, fashion fine ingredients". We are also the first company that introduced the "Molecular Gastronomy" cooking equipment and molecular food raw materials to the mainland of China.

We try to provide restaurants, bars, coffee shops and chain eatery with fashion, excellent, high quality catering kitchen equipment, molecular cuisine kitchen equipment and a selection of fine ingredients around the world.

Our company intergrates multiple systems, such as professional imports, product research and development, technical support, product sales, maintenance services, series supporting, counseling training and so on to provide personalized solutions timely.

品尚烹饪技术有限公司，创立于2008年，是一家专注于“时尚餐饮设备、时尚用品用具，时尚精细食材”的独特专业化公司，也是第一家把“分子美食”烹饪设备，原料引进内地的企业。

我们竭力为餐厅、酒吧，咖啡店以及餐饮连锁企业提供时尚，精良，质优的餐饮厨房设备，分子美食厨房设备及全球精选精细食材。

公司通过专业进口，产品研发，技术支持，产品销售，维修服务，系列配套，咨询培训等多个系统的整合；努力实现个性化的及时方案提供。



04

SOUS VIDE COOKER
低温慢煮机

07

VACUUM PACKAGING MACHINERY
真空包装机械

10

VACUUM BAGS OF FOOD PACKAGING
食品包装真空袋

11

TAURUS PROFESSIONAL ROWZER
万能冰磨机

12

TAURUS PROFESSIONAL MYCOOK
多功能食品料理机

13

ICC COOKING CONCEPTS
ICC厨房设备

14

FOOD SOMKER & WOOD CHIPS
烟熏机和烟熏木

15

ISI CHIP PRODUCTS
ISI奶油瓶

16

NATURAL CUTTLFISH INK
西班牙进口天然墨鱼汁

17

MOLECULAR GASTRONOMY
分子美食原料

VP160

真空包装机
VACUUM SEALER

Model型号: VP160	EAN13: 6971656300117
220V/50Hz	↔ 36X49X21 cm
250W	⚖ 20 Kg

NEW

2 Filler Plates
填充板2块



Sealing bar: 26 cm
封口条长: 26 cm



Perfect design
完美设计



Suction: 4m³/h
抽气率: 4m³/h

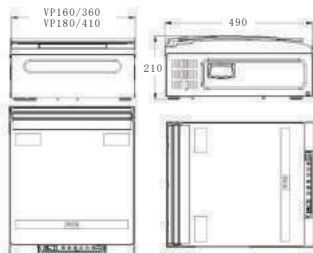

- Vacuum chamber size 305X300X110mm · 真空室尺寸 305X300X110 毫米
 - Vacuum chamber volume ≈7L · 真空室容积 ≈7 升
 - Sealing dimension 260X6mm · 封口尺寸 260X6 毫米
 - Spacer dimension 260X180X20mm · 垫板尺寸 260X180X20 毫米
 - Gas extraction rate 4m³/h ≥-0.09Mpa · 抽气率 4 立方米/小时 ≥-0.09Mpa
- LED触摸屏 · 中英界面可选 · 可预设10种工作程序 · 超大真空室 · 送外抽接头及真空罐

VP180

真空包装机
VACUUM SEALER

Model型号: VP180	EAN13: 6971656300124
220V/50Hz	↔ 36X49X21 cm
250W	⚖ 24 Kg

2 Filler Plates
填充板2块



Sealing bar: 31 cm
封口条长: 31 cm



Perfect design
完美设计



Suction: 4m³/h
抽气率: 4m³/h

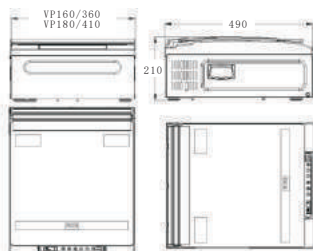

- Vacuum chamber size 355X300X110mm · 真空室尺寸 355X300X110 毫米
 - Vacuum chamber volume ≈9L · 真空室容积 ≈9 升
 - Sealing dimension 310X6mm · 封口尺寸 310X6 毫米
 - Spacer dimension 310X180X20mm · 垫板尺寸 310X180X20 毫米
 - Gas extraction rate 4m³/h ≥-0.09Mpa · 抽气率 4 立方米/小时 ≥-0.09Mpa
- LED触摸屏 · 中英界面可选 · 可预设10种工作程序 · 超大真空室 · 送外抽接头及真空罐

VP-200

真空包装机
VACUUM SEALER



Model型号: VP200	EAN13: 6971656300131
220V/50Hz	↔ 48x33x35,6 cm
1100W	⚖ 26,7 Kg



Sealing bar: 26.5 cm
封口条长: 26.5 cm



Pressure: -29.7"Hg / -1006mbar (± 5%)
压力: -29.7"Hg / -1006mbar (± 5%)

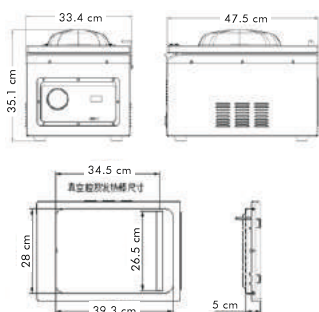

- Voltage: 220Vac 50Hz
- Power: 1100W
- Vacuum pump: dry pump
- Pressure: -29.7"Hg / -1006mbar (± 5%)
directly in pump
- -29.5 "Hg/-999mbar (± 5%)
in vacuum chamber
- Max bag width: 260mm
- Seal wire width: 5 mm
- Size: 480x330x356mm

- 电压: 220V/50Hz
- 功率: 1100W
- 真空泵: 干泵
- 压力: -29.7 "Hg / -1006mbar (±5%)
直抽真空泵
- -29.5 "Hg / -999mbar (±5%) 真空腔
- 最大袋宽: 260mm
- 发热丝宽: 5 mm
- 尺寸: 480x330x356mm

VP-300

真空包装机
VACUUM SEALER



Model型号: VP300	EAN13: 6971656300148
220V/50Hz	↔ 56,7x49,5x47,2 cm
1100W	⚖ 60 Kg



2 Filler Plates
填充板2块



Sealing bar: 41 cm
封口条长: 41 cm



Pressure: -29.9"Hg / -1012mbar (+0-3%)
压力: -29.9"Hg / -1012mbar (+0-3%)

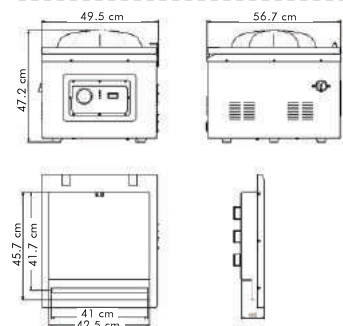

- Voltage: 220Vac 50Hz
- Power: 1100W
- Vacuum pump: Oil pump
- Pressure: -29.9"Hg / -1012mbar (±3%)
directly in pump
- -29.8"Hg / -1009mbar(±3%)
in vacuum chamber
- Max bag width: 410mm
- Seal wire width: 3.5 mmx2
- Size: 576x495x472mm

- 电压: 220V/50Hz
- 功率: 1100W
- 真空泵: 油泵
- 压力: -29.9" Hg / -1012mbar (±3%)
直抽真空泵
- -29.8" Hg / -1009mbar(±3%)真空腔
- 最大袋宽: 410mm
- 发热丝宽: 3.5 mm X 2
- 尺寸: 576x495x472mm

VP-400

真空包装机

VACUUM SEALER

Model型号: VP400	EAN13: 6971656301206
220V/50Hz	↔ 56,7x50,5x47,2 cm
1100W	⚖ 6.0Kg 双封口条



2 Filler Plates
填充板2块



Double sealing bar
双封口条

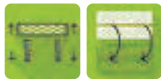

Double sealing bar: 43.2 cm
双封口条: 43,2 cm



Pressure: -29.9" Hg / -1012mbar (+0-3%)
压力: -29.9" Hg / -1012mbar (+0-3%)

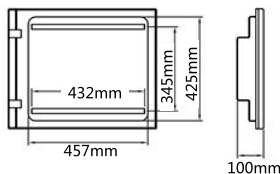
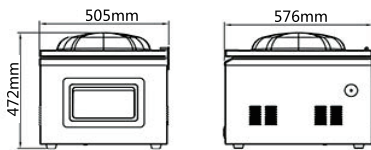

- Voltage: 220Vac 50Hz
- Power: 1100W
- Vacuum pump: Oil pump
- Pressure: -29.9" Hg / -1012mbar (±3%)
directly in pump
-29.8" Hg / -1009mbar(±3%)
in vacuum chamber
- Seal bar: 2pcs
- Seal bar length: 432mm/17"
- Seal wire width: 3.5 mmx2
- Size: 576x505x472mm

- 电压: 220V/50Hz
- 功率: 1100W
- 真空泵: 油泵
- 压力: -29.9" Hg / -1012mbar
(±3%) 直抽真空泵
-29.8" Hg / -1009mbar
(±3%) 真空腔
- 封口条: 2条
- 封口长: 432mm
- 发热丝宽: 3.5 mm X 2
- 尺寸: 567x505x472mm

CREATIVECHEF

SOUS VIDE COOKER

低温慢煮机

SV700

低温慢煮机
SOUS VIDE COOKER

Model型号: SV700	EAN13: 6971656301114
220V/50Hz	↔ 35.5X27X24 cm
700W	🗄 8 L



- Rated voltage: 220-240V
- Rated frequency: 50HZ
- Rated power: 700 W
- Temperature setting range: 40—90 °C
- Time setting range: 10 min—72 hours

- 额定电压：220-240V
- 额定频率：50HZ
- 额定功率：700 W
- 温度设定范围：40 ---- 90°C
- 时间设定范围：10分钟 - 72小时

SV800

低温慢煮机
SOUS VIDE COOKER

Model型号: SV800	EAN13: 6971656308885
220V/50Hz	800W



- Rated voltage: 230V
- Rated frequency: 50HZ
- Rated power: 800W
- Temperature setting range: 0—85 °C
- Time setting range: 0—60 hours

- 额定电压：230 V
- 额定频率：50HZ
- 额定功率：800 W
- 温度设置范围：0----85 °C
- 时间设置范围：0---60hours

SV1300

低温慢煮机
SOUS VIDE COOKER

Model型号: SV1300	EAN13: 6971656300186
230V/60Hz	1300W



- Rated voltage: 220-240V
- Rated frequency: 50HZ-60HZ
- Rated power: 1300 W
- Temperature setting range: 5—95 °C / 41—203 °F
- Time setting range: 0—99 hours 59min
- Display accuracy: 0.1

- 额定电压：220-240 V
- 额定频率：50HZ-60HZ
- 额定功率：1300 W
- 温度设置范围：5----90 °C
- 时间设置范围：0---99 hours 59min
- 显示精度：0.1

SV1600

低温慢煮机

SOUS VIDE COOKER

NEW
IPX7

Model 型号: SV1600	EAN13: 6971656300179	
220V/50Hz	1600W	↔ 9.3x5.9x33.9 cm
防水等级:IPX7	控水38L	⚖ 1.6 Kg WiFi connectivity



- Rated voltage: 220-240V
- Rated frequency: 50HZ-60HZ
- Rated power: 1600 W
- Temperature setting range: 5—95 °C / 41—203 °F
- Time setting range: 5 min—99 hours 59min
- Display accuracy: 0.1
- Size: 93x59x339mm
- Weight: 1.6 Kg

- 额定电压：220-240 V
- 额定频率：50HZ-60HZ
- 额定功率：1600 W
- 温度设置范围：5---95 °C / 41---203 °F
- 时间设置范围：5 min---99 hours 59min
- 显示精度：0.1
- 尺寸：93x59x339mm
- 重量：1.6 Kg

SV2300

低温慢煮机

SOUS VIDE COOKER

NEW
IPX7

Model 型号: SV2300	EAN13: 6971656300186	
230V/60Hz	2300W	↔ 14x14.3x30.2 cm
防水等级:IPX7	控水80L	⚖ 2.2 Kg WiFi connectivity



- Rated voltage: 220-240V 50HZ-60HZ
- Rated power: 2300 W
- Maximum water control:80L
- Temperature setting range: 5—95 °C / 41—203 °F
- Time setting range: 5 min—99 hours 59min
- Display accuracy: 0.1
- Size: 140x143x302mm
- Weight: 2.2 Kg

- 额定电压：220-240 V , 50HZ-60HZ
- 额定功率：2300 W
- 最大控水量：80升
- 温度设置范围：5---95 °C / 41---203 °F
- 时间设置范围：5 min---99 hours 59min
- 显示精度：0.1
- 尺寸：140x143x302mm
- 重量：2.2 Kg

THE SMARTVIDE RANGE

SOUS VIDE COOKER

低温慢煮机

SMARTVIDE 4

智能低温慢煮机4
SOUS VIDE COOKER

Code编码:1180040	28-38L
220V	↔ 11.2x12.7x33.5 cm
1600W	⚖ 2.7 kg



- Max.recipient capacity: 28-38L
- Display precision: 0.01 °C
- Total loading: 1600 W
- Temperature setting range: 5—95 °C
- Time setting range: 1 min—99 hours
- 最大容量：28-38L
- 温度精确度：0.01 °C
- 总功率：1600 W
- 温度设定范围：5 ---- 95°C
- 时间设定范围：1分钟 - 99小时

SMARTVIDE 6

智能低温慢煮机6
SOUS VIDE COOKER

Code编码:1180020	56 L
220V	↔ 12.4x14x36 cm
2000W	⚖ 3.5 kg



- Max.recipient capacity: 56 L
- Display precision: 0.01 °C
- Total loading: 2000 W
- Temperature setting range: 5—95 °C
- Time setting range: 1 min—99 hours
- 最大容量：56 L
- 温度精确度：0.01 °C
- 总功率：2000 W
- 温度设定范围：5 ---- 95°C
- 时间设定范围：1分钟 - 99小时

SMARTVIDE 8

智能低温慢煮机8
SOUS VIDE COOKER

Code编码：1180000	56 L
220V	↔ 12.4x14x36 cm
2000W	⚖ 3.5 kg



- Max.recipient capacity: 56 L
- Display precision: 0.01 °C
- Total loading: 2000 W
- Temperature setting range: 5—95 °C
- Time setting range: 1 min—99 hours
- Core probe: Optional
- Panel /handle: Stainless steel
- 最大容量：56 L
- 温度精确度：0.01 °C
- 总功率：2000 W
- 温度设定范围：5 ---- 95°C
- 时间设定范围：1分钟 - 99小时
- 温度探针：选配
- 面板/手柄：优质不锈钢

CREATIVECHEF BAGS FOR VACUUM PACKAGING 真空包装袋

Bags especially Designed for SOUS VIDE

低温慢煮专用袋 (平面袋)

The multilayer system of Elma's bags guarantees a secure and durable sealing for your food

Material quality 材质: PA+CPP

Temperature 耐高温: 121 °C / 249.8 °F

Application 适用于: 

cm	EAN13	Piece / □
Bags 15 x 20 cm	6971656300056	100
Bags 20 x 30 cm	6971656300063	100
Bags 30 x 40 cm	6971656300070	100





适用于低温慢煮的烹饪方式

Vacuum Bags of Food Packaging 食品真空包装袋 (网纹袋)

Material quality 材质: PA+CPP

Temperature 耐高温: 100 °C

Application 适用于:  

cm	EAN13	Piece / □
Bags 7 x 10 cm	6971656300001	100
Bags 15 x 20 cm	6971656300025	100
Bags 20 x 30 cm	6971656300032	100
Bags 28 x 40 cm	6971656300049	100



适用于低温慢煮的烹饪方式

Vacuum Food Zipper Bags 真空食品拉链袋

Material quality 材质: PA+PE

Temperature 耐高温: 100 °C

Size 尺寸: 21 x 22cm / 26 x 28cm



适用于低温慢煮的烹饪方式



Secure bags
袋子安全可靠



The freshness of the food is extended
4 times longer
4倍延长食品的新鲜程度



They keep the nutritional
attributes of the food
锁住食物的营养



NEW FORMULA
新配方

ROWZER

万能冰磨机

WHATEVER ICE-CREAM

Code编码:926001

220V,50/60Hz \leftrightarrow C47.5X A19X B33.5 cm

1050W \updownarrow 15 Kg

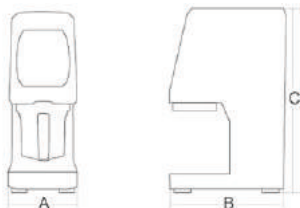

ROWZER PLUS

万能冰磨机

WHATEVER ICE-CREAM

Code编码:92601230

220V,50/60Hz \leftrightarrow C47.5 X A19X B39.5 cm

1000W \updownarrow 18 Kg

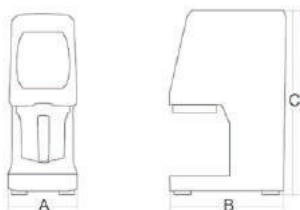

A special designed shaving blade
独创研磨刀片



One active carbon air filter, externally placed, for an easy regular renewal by the user
活性炭空气过滤芯



Two stainless steel jars with lid, marked for 10 portions
两个不锈钢钢杯



Jar holder with sealing lid.
黑色外罐，黑色刀座

MYCOOK1.6

多功能食物料理机1.6
IT REALLY COOKS

220-240V	Code编码:93001000
50/60Hz	↔ C29 X A35 X B27 cm
1600W	

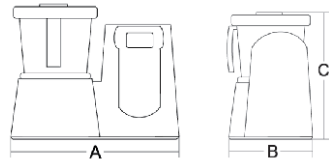

MYCOOK1.8

多功能食物料理机1.8
IT REALLY COOKS

220-240V	Code编码:926019
50/60Hz	↔ C29 X A35 X B27 cm
1800W	⚖ 7.8 Kg

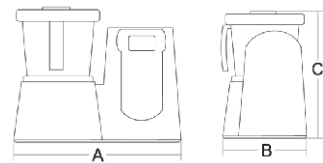

Spatula/ Mixing Paddle/4 Stainless steel blades
橡胶铲/搅拌桨/不锈钢4页刀片



2 Levels Stainless steel steamer
2层式不锈钢蒸锅



2Stainless Steel Cup
2个不锈钢杯



恒温器

SOU SVIDE RONER

Code:80013
Weight: 4 Kg
Power: 2060W
Voltage: 230V 50-60Hz
Size: 28 X 18 X 19 CM

编码：80013
重量：4公斤
功率：2060W
电压：230V 50-60Hz
尺寸：28 X 18 X 19 CM



恒温器触摸屏

SOU SVIDE RONER TOUCH

Code:80012
Weight: 4 Kg
Power: 2060W
Voltage: 230V 50-60Hz
Size: 28 X 18 X 19 CM

编码：80012
重量：4公斤
功率：2060W
电压：230V 50-60Hz
尺寸：28 X 18 X 19 CM



低温烹饪机20升

SOU SVIDE RONER COMPACT 20L

Code:80060
Weight: 15 Kg
Power: 2000W
Voltage: 230V/50Hz
Size: 26 X 37 X 67 CM

编码：80060
重量：15公斤
功率：2000W
电压：230V/50Hz
尺寸：26 X 37 X 67 CM



低温烹饪机45升

SOU SVIDE RONER COMPACT 45L

Code:80020
Weight: 21 Kg
Power: 2400W
Voltage: 230V/50Hz
Size: 27 X 70 X 67 CM

编码：80020
重量：21公斤
功率：2400W
电压：230V/50Hz
尺寸：27 X 70 X 67 CM



低压真空烹饪机

GASTROVAC

Code:20000
Weight: 11 Kg
Power: 2000W
Voltage: 220V/50Hz
Size: 40 X 47 X 47 CM

编码：20000
重量：11公斤
功率：2000W
电压：220V/50Hz
尺寸：40 X 47 X 47 CM



食品蒸发器

ROTAVAL MICRO

Code:80045
Weight: 34 Kg
Power: 1800W
Size: 64 X 43 X 42 CM

编码：80045
重量：34公斤
功率：1800W
尺寸：64 X 43 X 42 CM



EZIDRI FD1000

纽西兰蔬果风干机

Code:FD1000
Weight: 4.7 Kg
Power: 1000W
Voltage: 220V/50Hz
Size: 39 X 39 X 28 CM



编码 : FD1000
重量 : 4.7公斤
功率 : 1000W
电压 : 220V/50Hz
尺寸 : 39 X 39 X 28 CM

GEO Croquanter 脱水模具

Code编码:100411



Natur Croquanter 花朵模具

Code编码:102102



FOOD SMOKER

食物烟熏机SG28

EAN13: 6971656300230
Size尺寸: D84x100x190 mm



FOOD SMOKER

食物烟熏机 SG18

EAN13: 6971656300223
Size尺寸: 117x36x36 mm



FOOD SMOKER

食物烟熏机 SG16

EAN13: 6971656301114
Size尺寸: 155x68x44 mm



PECAN WOOD CHIPS

山核桃木烟熏料120g

Code编码:CACC107



APPLE WOOD CHIPS

苹果木烟熏料120g

Code编码:CACC108



CHERRY WOOD CHIPS

樱桃木烟熏料120g

Code编码:CACC109



EASY COOK

耐高温烹饪纸50*10米

Code编码:S03



EASY COOK 25pcs

耐高温烹饪纸 25张/包

Code编码:S01



ISI

多功能奶油瓶 冷/热用
GOURMET WHIP PLUS

Code: 1603/1703
Capacity: 0.5 L/1 L
Dimension: 9.4×9.4×29.3cm/
10.2×10.2×33.6cm

编码: 1603/1703
容量: 0.5 L/1 L
尺寸: 9.4×9.4×29.3cm/
10.2×10.2×33.6cm



ISI

恒温真空奶油瓶 冷/热用
THERMO WHIP PLUS

Code: 1801
Capacity: 0.5 L
Dimension: 10.2×10.2×29.1cm

编码: 1801
容量: 0.5 L
尺寸: 10.2×10.2×29.1cm



ISI

普通型奶油瓶 冷用
CREAM PROFI WHIP

Code: 1630/1730
Capacity: 0.5 L/1 L
Dimension: 9.4×8.2×29.2cm/
10.2×10.2×33.6cm

编码: 1630/1730
容量: 0.5 L/1 L
尺寸: 9.4×9.4×29.3cm/
10.2×10.2×33.6cm



ISI

苏打瓶
SODASIPHON

Code: 2246/2247/2248
Capacity: 0.75 L/1 L
Color: Red, Silver, Black
Dimension: 10×10×32cm

编码: 2246/2247/2248
容量: 0.75 L/1 L
颜色: 红色, 银色, 黑色
尺寸: 10×10×32cm



ISI

奶油气囊
CREAM CHARGER

Code: 008099
Package: 10 pcs/box

编码: 008099
包装: 10个/盒



ISI

苏打气囊
SODA CHARGER

Code: 001499
Package: 10 pcs/box

编码: 001499
包装: 10个/盒



ISI

装饰花嘴
DECORATOR TIPS
Code编码: 2715



ISI

不锈钢花嘴
STAINLESS STEEL TIPS
Code编码: 2717



ISI

不锈钢注射针4支
INJECTOR TIPS
Code编码: 2718



ISI

漏斗及筛网
FUNNEL & SIEVE
Code编码: 2704



天然墨鱼汁4份4克装

NATURAL CUTTLEFISH INK

Code:NCI0404
Weight: 4g*4

编码 : NCI0404
重量 : 4克*4



天然墨鱼汁180克装

NATURAL CUTTLEFISH INK

Code:NCI0180
Weight: 180g

编码 : NCI0180
重量 : 180克



天然墨鱼汁500克装

NATURAL CUTTLEFISH INK

Code:NCI0500
Weight: 500g

编码 : NCI0500
重量 : 500克



天然墨鱼汁1000克装

TINTA DE SEPIA

Code:TDS5004
Weight: 1000g

编码 : TDS5004
重量 : 1000克



西班牙海鲜饭酱200克

PAELLA SAUCE

Code:PS0200
Weight: 200 g

编码 : PS0200
重量 : 200克



TEXTURAS SFERIFICACIÓN (SPHERIFICATION) 球化系列

Code编码:250047
Texturas Algin
特奇乐牌圆球形海藻素
Weight重量: 500g



Code编码:250033
Texturas Calcic
特奇乐牌钙粉
Weight重量: 600g



Code编码:250048
Texturas Citras
特奇乐牌柠檬酸调节剂
Weight重量: 600g



Code编码:250066
Texturas Gluco
特奇乐牌葡萄糖调节剂
Weight重量: 600g



Code编码:100366
Texturas Eines
特奇乐牌球化工具
Herramientas



TEXTURAS GELIFICACIÓN (GELATINS) 凝胶系列

Code编码:190042
Texturas Agar
特奇乐牌高温琼脂
Weight重量: 500g



Code编码:250061
Texturas Kappa
特奇乐牌软性卡拉胶
Weight重量: 400g



Code编码:250087
Texturas Lota
特奇乐牌乳制卡拉胶
Weight重量: 500g



Code编码:250060
Texturas Gellan
特奇乐牌高温明胶
Weight重量: 400g



Code编码:250063
Texturas Metil
特奇乐牌蔬菜纤维素胶
Weight重量: 300g



Code编码:250222
Texturas Gelly
特奇乐牌超级明胶
Weight重量: 600g



TEXTURAS EMULSIFICACIÓN (EMULSIFICATION) 乳化系列

Code编码:250074
Texturas Lecite
特奇乐牌气泡卵磷脂
Weight重量: 300g



Code编码:250062
Texturas Suero
特奇乐牌气泡糖
Weight重量: 600g



Code编码:250065
Texturas Glice
特奇乐牌乳化剂
Weight重量: 300g



TEXTURAS ESPESANTES (THICKENER) 增稠系列

Code编码:191821
Texturas Xantana
特奇乐牌黄原胶
Weight重量: 600g



TEXTURAS 2018

Code编码:190006
Espuma Hot-cold foam
冷热泡沫定型粉
Weight重量: 500g



Code编码:250033
Dextrosa
食用葡萄糖粉 (冰淇淋稳定剂)
Weight重量: 5000g



TEXTURAS SURPRISES惊喜系列

Code编码:250205
Texturas Azuleta
特奇乐牌紫罗兰糖
Weight重量: 1000g



Code编码:250037
Texturas Manitol
特奇乐牌甘露糖醇
Weight重量: 700g



Code编码:250206
Texturas Sparkys
特奇乐牌跳跳糖
Weight重量: 210g



Code编码:250207
Texturas Cocolate Sparkys
特奇乐牌巧克力跳跳糖
Weight重量: 210g



Code编码:250067
Texturas Malto
特奇乐牌麦芽糖
Weight重量: 1000g



Code编码:250076
Texturas Fizzy
特奇乐牌发泡剂
Weight重量: 300g



Code编码:250043
Texturas Crumiel
特奇乐牌酥脆粉
Weight重量: 400g



Code编码:250054
Texturas Trisol
特奇乐牌小麦纤维粉
Weight重量: 4000g



Code编码:250055
Texturas Crutomat
特奇乐牌脱水西红柿粉
Weight重量: 400g



Code编码:250058
Texturas Yopol
特奇乐牌植物脂肪
Weight重量: 400g



Code编码:100288
Texturas Crurice
特奇乐牌酒香米
Weight重量: 400g



MUGARITZ

Code编码:810018
MUGARITZ Agalita
高岭粉
Weight重量: 750g



Code编码:810001
MUGARITZ KUZU
葛根
Weight重量: 500g



Code编码:810021
MUGARITZ LACTOSE
乳糖
Weight重量: 750g



Code编码:810019
MUGARITZ Calx
灰石粉
Weight重量: 750g



Code编码:810005
MUGARITZ Linum
亚麻籽
Weight重量: 500g



Code编码:810023
MUGARITZ Black Quinoa
黑藜麦
Weight重量: 1000g



TEXTURAS 2018

Code编码:CACC101
CAVIAR BOX
鱼子酱制作器 96眼



Code编码:CACC102
LOTUS SPOON
球化工具漏勺



Code编码:CACC103
Jeringa de Texturas
特奇乐鱼子酱注射器



Code编码:CACC104
Precision Scale 0,01 g
精密电子称0.01克

